

OPERATING INSTRUCTIONS AND MAINTENANCE MANUAL FOR HIGH PRESSURE PISTON PUMPS

INDEX

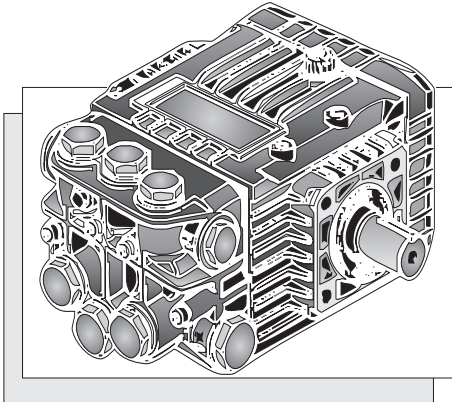

Fig.1a- A&R pump XT 8.14N - Dx (RHS)

	Page
General technical features of high pressure pumps	1
SAFETY STANDARDS	1
Installation	2
Input water supply	2
Before starting up	2
During running	3
Switching off and storing precautions	3
Trouble shooting	3
Maintenance standards	4 ÷ 6
Gearbox assembly XT - XR	6
Charts	8

GENERAL TECHNICAL FEATURES OF HIGH PRESSURE PUMPS

The range of A/R plunger pumps is used with flows from 8 to 40 Litres/min. (2.1 to 11 gpm) and with maximum pressures of 250 bar (3600 PSI). Each type of pump is designed and developed to work at the performance indicated on the pumps nameplate.

If, infact, the flows depends upon:

- a) the diameter of the piston,
- b) the stroke of the piston,
- c) the number of pistons,
- d) the number of stokes for minute;

ANNOVI REVERBERI		XT 8.14	
VOLUME	8 L/min	kw	2,2
PRESS.	140 bar	HP	3
R. P. M.	1450		

Fig.2a- Nameplate

the pressure generated by the pump depends upon the choice of the nozzle, **IT IS THEREFORE A NECESSITY THAT THE PRESSURE AND THE R.P.M. REMAIN WITHIN THE MAXIMUM VALUES INDICATED.**

The pumps are made of special materials, which are resistant to corrosion such as stainless steel, ceramic compounds, brass and aluminium alloys with protective treatments.

Ceramic pistons, moving parts in an oil bath, oil level dipstick and oil level window for quick check. High quality packings with easy access, making for rapid maintenance, as well as inspection friendly suction/outlet valves. The hydraulics are separated from the crank mechanism with a recovery and recycling system for leaks, thereby avoiding the pollution of the lubricating oil.



ATTENTION



SAFETY STANDARDS

- Do not spray persons or animals with a high pressure jet.
- If driven by an electric motor, the machine must be equipped with a protective circuit which guarantees the operator's safety from high voltage.
- If driven by a gas engine, do not use the unit indoors. Discharge gases include carbon monoxide an odourless but lethal gas.

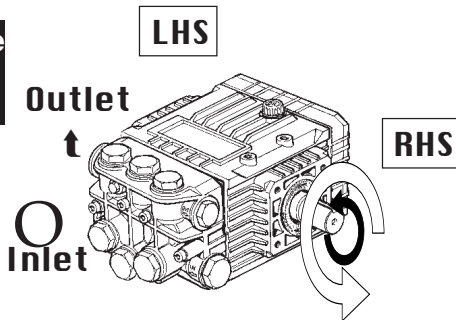

Fig. 1b- The pump can rotate either in clockwise or anticlockwise direction.

INSTALLATION

The pump must be installed horizontally, blocked in a stable manner, by means of the coupling flanges suitable for the type of motor/engine with which the pump will be driven. If pulley drive is used, you must have a protection guard.

The pumps can rotate either clockwise or anticlockwise.

Suction and outlet piping can be attached either to the left hand side or right hand side of the pump.

The suction hose must:

- be of a diameter equal to from 1 to 1.5 times the suction part of the pump,
- set up in such a way as to avoid the forming of air pockets,
- be as short as possible and hermetically attached to the pump to avoid sucking air.

Below please find an example of a correct installation:

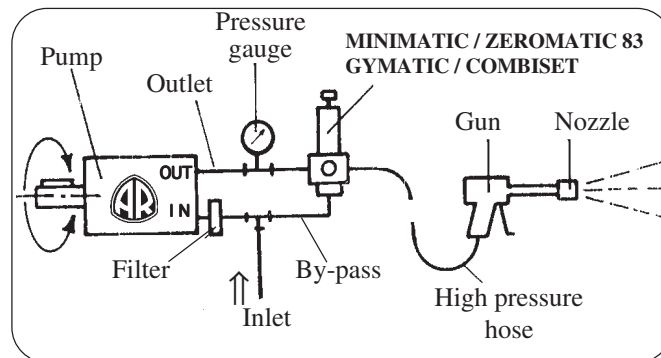

Fig. 2b- Installation schematic with pressure regulating valve

INPUT WATER SUPPLY

Utilize liquids free from impurities (such as sand or other solid particles which will affect the efficiency of the valves, the piston and the packings). For this reason it is advisable to fit a filter on the suction hose, with a large filtering surface and low load loss. Replace the filter as soon as it becomes clogged up, to avoid noisy operation and pulsations which can damage the mechanical parts of the pump. If the pump draws from a tank place the filter at the entrance of the same.

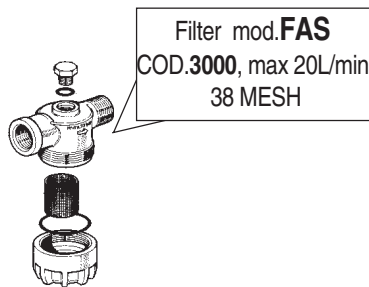

Fig. 4b- Check the suction filter periodically.

NB: Maximum temperature of pumped liquid is 60°C (140°F), maximum forced suction (measured at the pump) is 10 bar (145 PSI).

BEFORE STARTING UP

1. The pump is supplied complete with oil, so the first thing to do is remove the red cap utilized for transportation, and insert the dipstick which is supplied with the pump.
2. Check that oil is at the correct level, by means of the oil level window topping up if necessary using oil type indicated in chart 1.1 page 8.
3. Make sure that inlet water flow is sufficient-at least the same value as the pump flow and that it comes out without air bubbles.
4. Prime the pump with the outlet completely open.
5. Then start up the motor, if using a gas engine bring the RPM 's up to pre-set level.

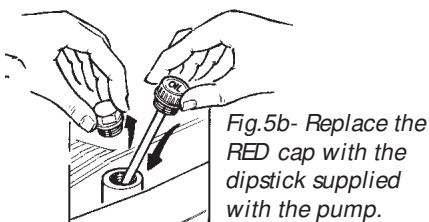

Fig. 5b- Replace the RED cap with the dipstick supplied with the pump.

DURING RUNNING

Check the efficiency of the hydraulic circuit whilst pump is running: drips or signs of wear on the hoses can cause injuries as well as prejudice the life and performance of the machine.

If the circuit recycles by means of a by-pass, avoid running the pump for long periods of time without pulling the trigger since this heats the liquid up and could damage the seals.

page
3

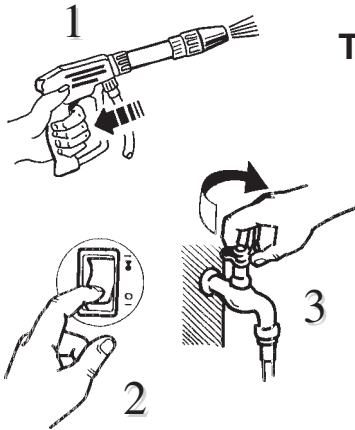

TURNING OFF AND STORING PRECAUTIONS

1. Pull the trigger whilst turning off the machine, to make sure no high pressure spraying is possible.
2. Turn off the motor.
3. Turn off inlet liquid supply.

STORING

If the pump is not used for more than 30 days, proceed as follows:

- empty it of all pumped liquid, taking care to do the same with all pipings and accessories,
- clean it by removing any calcareous deposits,
- wrap up in a protective cover,
- store in a clean and dry place, protected from frost.

TROUBLE SHOOTING

PROBLEM	CAUSE	REMEDY
The pump doesn't reach required pressure	Unsuitable or worn out nozzle Reg. valve seat worn out	Replace nozzle Replace valve seat
The pump is noisy	Pump sucking air	Check suction manifold
Pressure gauge fluctuates	Valves blocked by foreign bodies, or worn Packing worn High temperature of pumped liquid	Clean or replace valves Replace packing Reduce temperature of pumped liquid
Water leaks from the bottom of the pump	Piston packing worn	Replace piston packing
Water leaks from head	Head O-Ring worn	Replace O-Ring
Oil leaks from the bottom of the pump	Oil seals worn	Replace seals
Over pressure when gun is closed	Leaking in unloader valve and incorrect setting	Control the valve and set new pressure level

MAINTENANCE STANDARDS

page
4

before carrying out any maintenance whatsoever:
 - check that no part of the machinery is live;
 - if the pump is coupled to a gas engine, remove the spark plug.

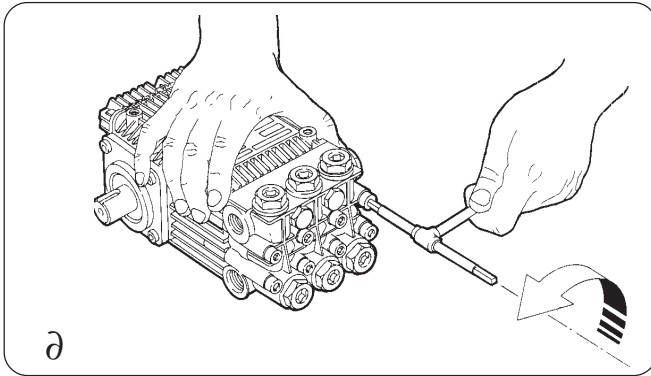

∂ Σ ASSEMBLY - DISASSEMBLY OF THE PUMP HEAD

1.1 - Unscrew head bolts.

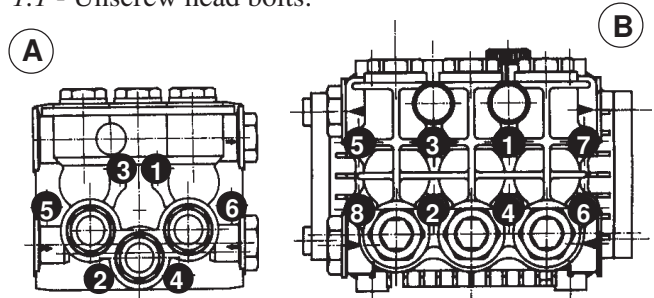

Tightening sequence of head bolts, **(A)** for XT Series and HPE Series, **(B)** for XR Series and XL Series.

For torque ratings see chart 1.2 page 8.

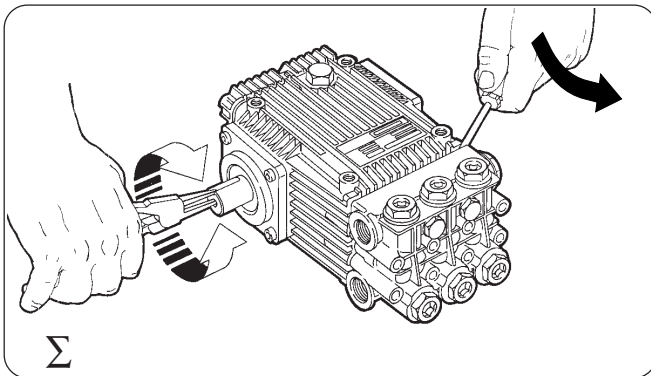

1.2 - Remove the head by rotating the shaft and levering between head and body.

1.3 - For re-assembly: Invert above instructions, and keep to torque rates shown on page 8.

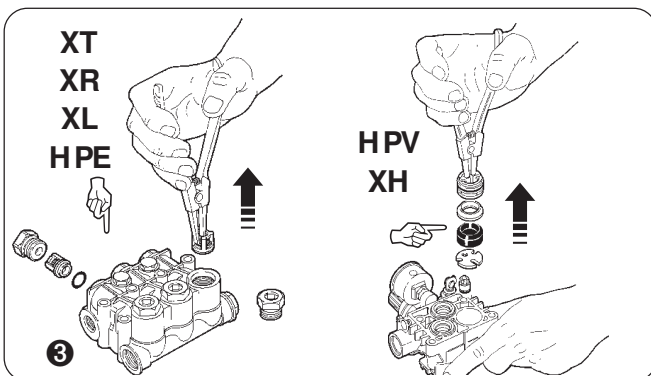

③ INSPECTING INLET/OUTLET VALVES

2.1 - Remove valve caps, slide out inlet/outlet valves check the condition of the various components of the valve and well as the O-Ring, replace if necessary.

2.2 - For re-assembly: Invert previous operation. Keep to torque ratings as shown on page 8.

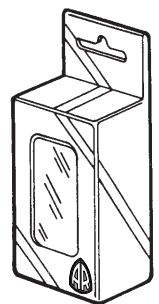

Valve kits (see parts catalogue)

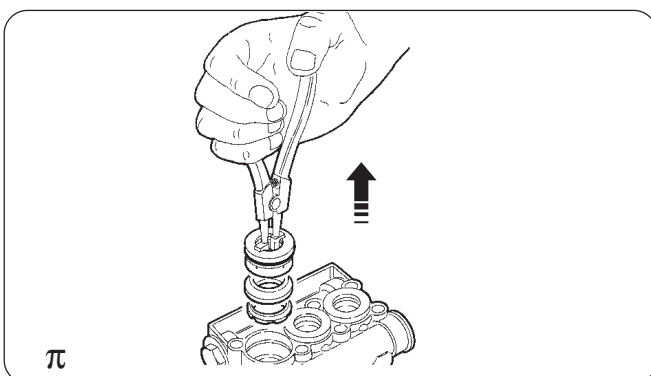

π ∫ REPLACING PACKING AND RECOVERY SEALS

3.1 - Remove the head (See ∂), then slide out piston guides, being careful not to deform them, using the special extractor pliers.

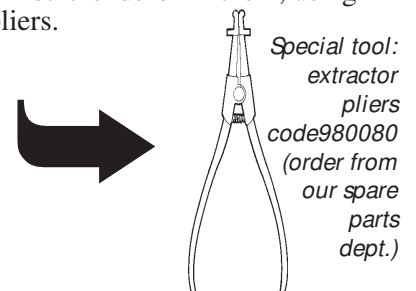

Special tool:
 extractor pliers
 code 980080
 (order from our spare parts dept.)

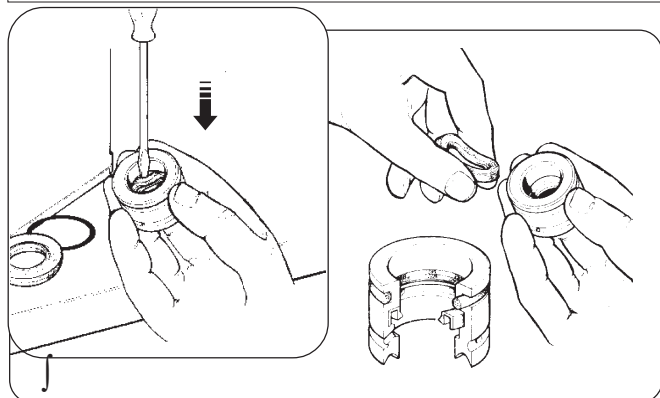

- CONTINUED: REPLACING PACKING AND RECOVERY SEALS

3.2 - Disassemble the components of the piston guide, checking the condition, replace if necessary.

3.3 - For re-assembly: Invert operation.

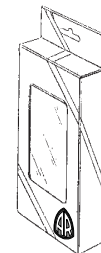

page
5

Seal kit (see parts catalogue)

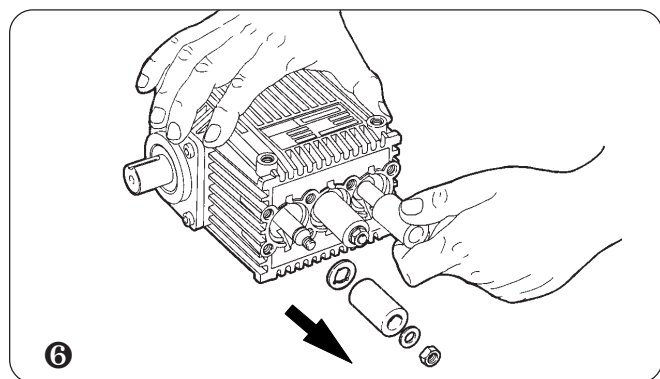

6 REPLACING THE PISTONS

4.1 - Remove the head (See 3), then unscrew the piston retainers.

4.2 - Slide off the ceramic pistons, check their condition, and replace if necessary.

4.3 - For re-assembly: Invert above operations. Keep to torque rating and shown on page 8.

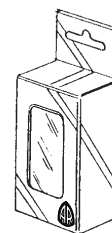

Piston kit (see parts catalogue)

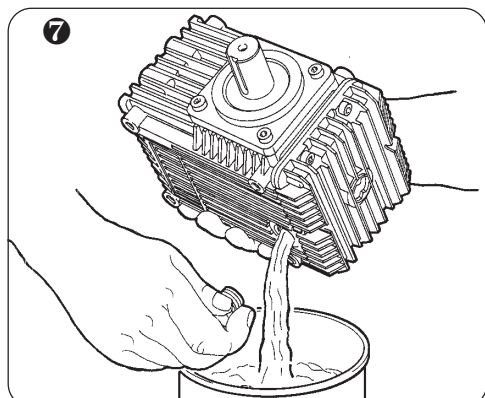

7 DISCHARGING OIL

5.1 - Remove oil dipstick, unscrew oil discharge plug, then lean the pump sideways to help empty the pump.



NB: Oil pollutes the environment! Do not pour down drain!!

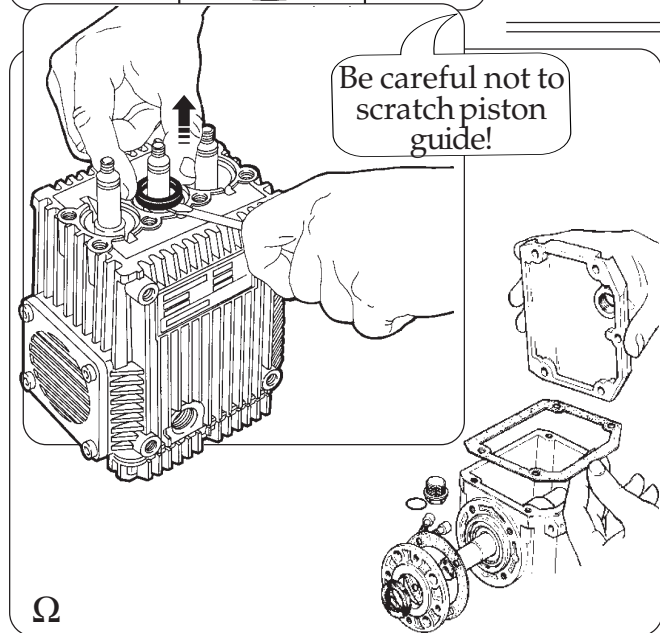

Ω REPLACING OIL SEALS

6.1 - Remove the head (See 3),
 • remove the ceramic pistons (See 6),
 • discharge oil (See 7).

6.2 - Remove the oil seals and the O-Rings, checking the seats and the piston guides.

6.3 - Remove the rear cover gasket.

6.4 - For re-assembly: Invert above operations. Keep to torque ratings as shown on page 8.

Oil seal kit (see parts catalogue)



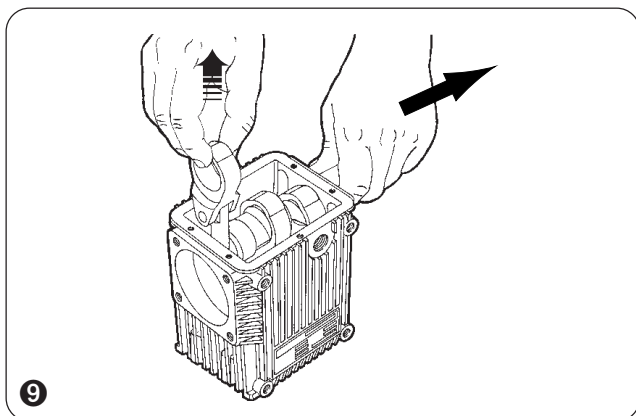

9 CRANK MECHANISM MAINTENANCE (EXCLUDING XR)

7.1 - Remove the head (See 3),
 • remove the ceramic pistons (See 6),
 • discharge oil (See 7).

7.2 - Remove the rear cover.

7.3 - Remove the con-rod sliding the one piece-rod whilst removing the shaft.

7.4 - For re-assembly: Invert above operations. Replace the oil seals!
 Keep to torque ratings as shown on page 8.

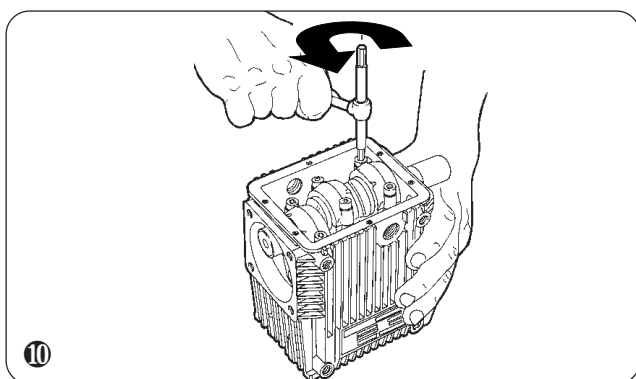

10 CRANK MECHANISM MAINTENANCE XR SERIES

8.1 - Remove the head (See 3),
 • remove the ceramic pistons (See 6),
 • discharge oil (See 7).

8.2 - Remove the rear cover.

8.3 - Unscrew con rod bolts, remove the con-rod cap, sliding the shaft out, mark the two sides of the con-rod for future reference.

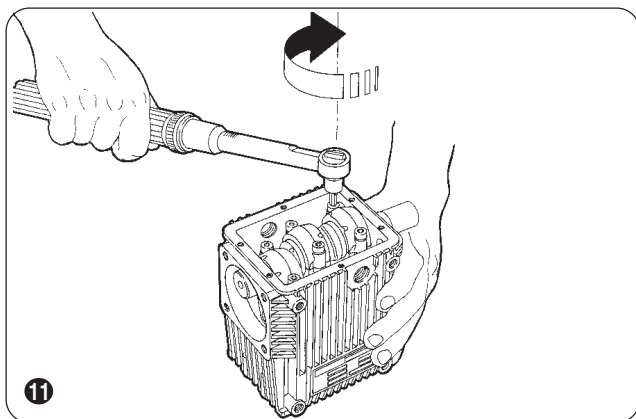

8.4 -For re-assembly: Invert above operations. Replace the oil seals!
 Keep to torque ratings as shown on page 8.

1 ÷ 9 GEARBOX ASSEMBLY XT - XR

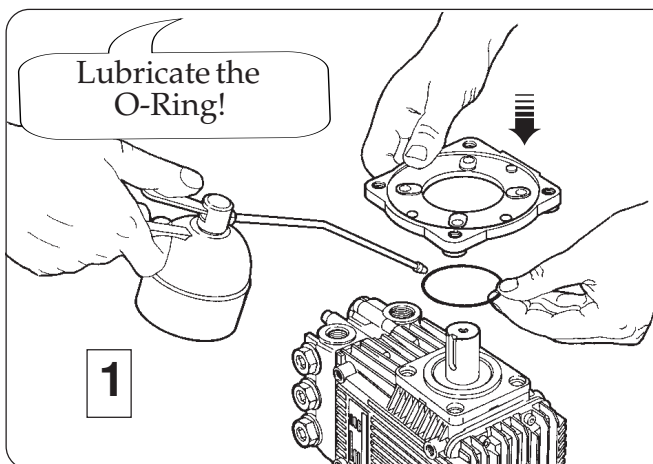

"PIK" sealing adhesive

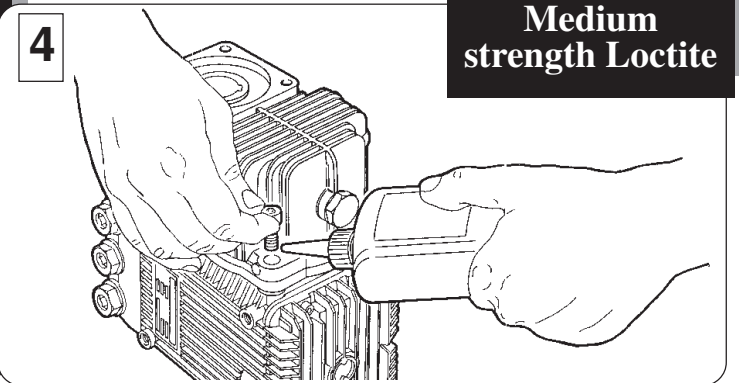
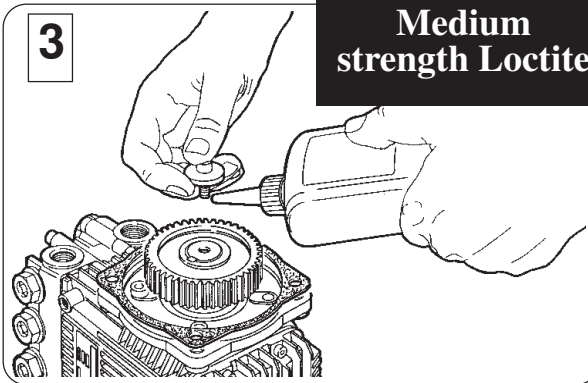

Assembly of bolts and spacer washers for flange for EUROPEAN and ITALIAN engines

NB! Keep the engine flange bolts loose.

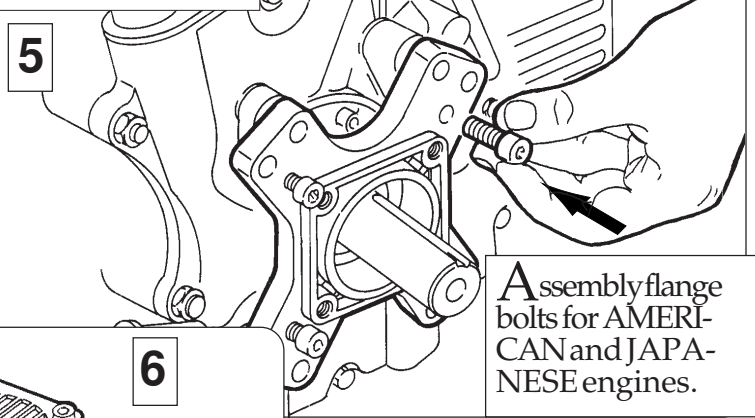
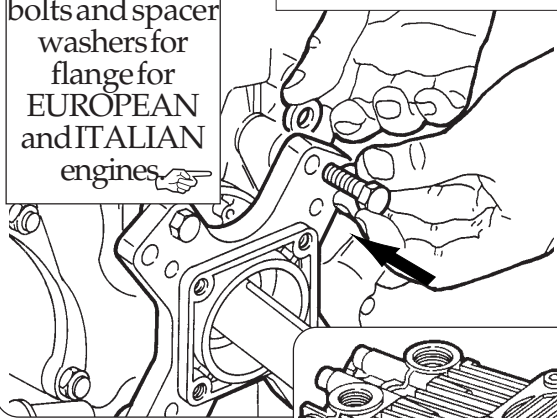

Assembly flange bolts for AMERICAN and JAPANESE engines.

± Tighten, with the special allen key supplied



code 1380630 the bolts between the gearbox and the engine flange.

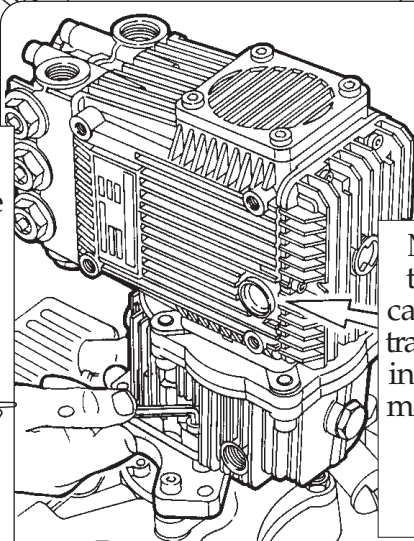

NB: Leave the red oil cap, used for transportation in place whilst mounting the gearbox.

△ Tighten fully, using the special allen key, the engine flange bolts.

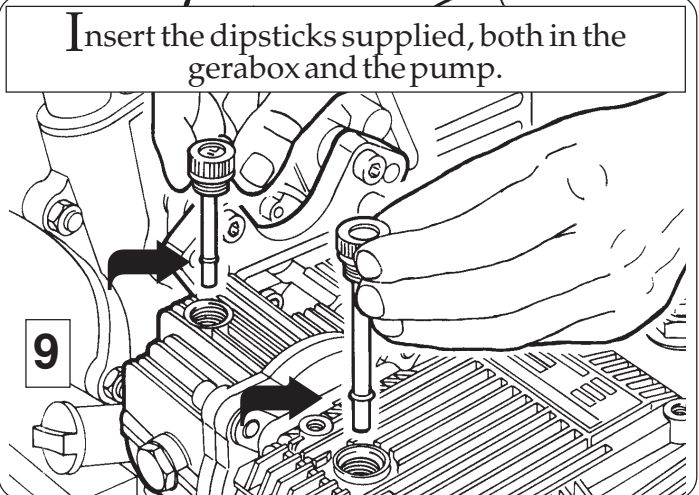
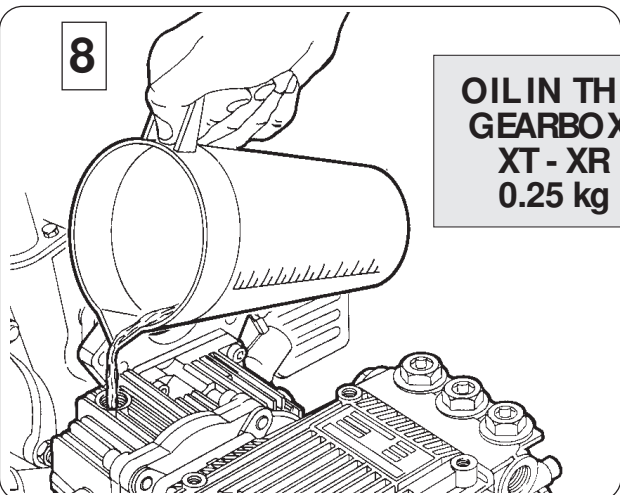
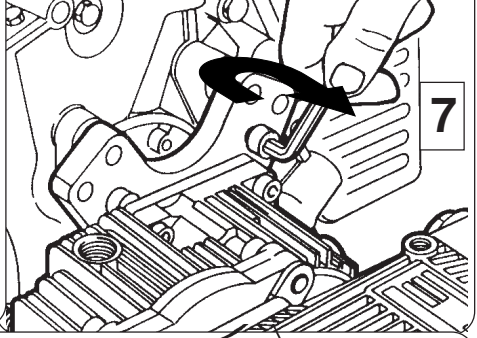

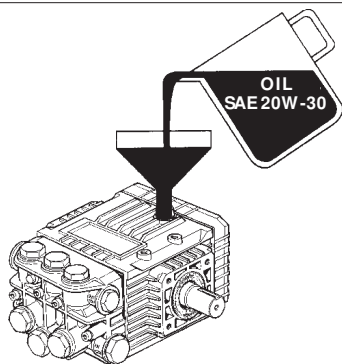

1.1 Oil chart

OIL WEIGHT
IN kg

	XT SERIES X.T. 175, X.TA. 17V	XR SERIES XR. 190, XR.V	XL SERIES XL. 16F	XH SERIES	HPE SERIES	HPV SERIES
Pump	0,23*	0,43	0,96	0,11	0,35	0,11
Gearbox	0,25	0,25	0,18	-	-	-
Overgear	-	0,2	-	-	-	-

Note:
* Add 0.05kg to versions with high rear cover

USE SAE 20W-30 OIL

Oil change:
- first change 50 hours,
- then every 500 hours.

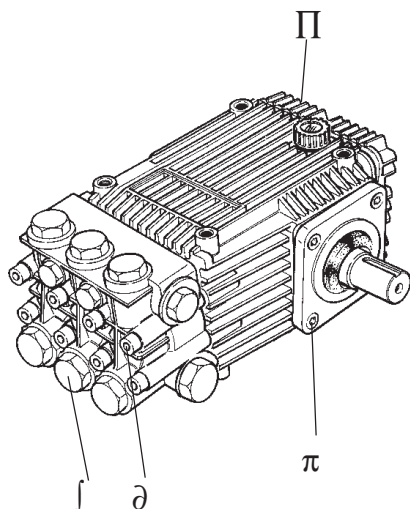

1.2 Torque ratings in Nm (kgm).

TORQUE RATINGS IN
Nm (kgm)

	XT SERIES X.T. 175, X.TA. 17V	XR SERIES XR. 190, XR.V	XL SERIES XL. 16F	XH SERIES	HPE SERIES	HPV SERIES
δ Head	10 (1)	24,5 (2,5)	24,5 (2,5)	10 (1)	10 (1)	10 (1)
Piston	10 ^b (1)	10 ^b (1)	19* (2)	5,4* (0,5)	10 ^b (1)	10* (1)
Π Rear cover	9 (0,9)	5,4 (0,5)	9 (0,9)	5,4 (0,5)	9 (0,9)	5,4 (0,5)
π Side cover	-	24,5 (2,5)	24,5 (2,5)	-	-	-
\int Valve caps	34 (3,5)	54 ^a (5,5)	54 (5,5)	-	34 (3,5)	-
Con rod bolts	-	9 (0,9)	-	-	-	-
Detergent suction coupling	-	-	-	11,7 (1,2)	-	11,7 (1,2)
Outlet coupling	-	-	-	27 (2,8)	-	27 (2,8)

Note:
a - For 250bar pumps medium strength Loctite
* - Medium strength Loctite
b - Max strength Loctite

1.3 Theoretical flow chart with pressures in bar, flows in L/min and equivalent nozzle diam. in mm.

NOZZLES TYPE MEG	bar Ømm	OUTPUT IN L/1' AT THE INDICATED PRESSURE																			
		20	30	40	50	60	70	80	90	100	110	120	130	140	150	160	170	180	200	220	250
..02	0,99	2,0	2,5	2,8	3,2	3,5	3,7	4,0	4,2	4,5	4,7	4,9	5,1	5,3	5,5	5,7	5,9	6,0	6,4	6,7	7,6
..03	1,09	3,1	3,7	4,3	4,8	5,3	5,7	6,1	6,3	6,8	7,2	7,4	7,7	8,0	8,3	8,7	8,9	9,2	9,6	10,0	11,4
..035	1,12	3,5	4,3	5,0	5,7	6,4	6,8	7,2	7,7	8,2	8,6	8,9	9,3	9,7	10,0	10,4	10,7	10,8	11,7	12,1	13,1
..04	1,19	4,2	5,2	5,9	6,6	7,3	7,8	8,4	8,9	9,4	9,8	10,3	10,7	11,1	11,5	11,9	12,2	12,4	13,2	14,1	14,8
..045	1,27	4,5	5,5	6,4	7,1	7,8	8,4	9,0	9,6	10,2	10,6	11,2	11,6	11,8	12,5	12,6	12,9	13,2	14,4	15,0	15,8
..05	1,35	5,0	6,2	7,1	8,0	8,7	9,4	10,0	10,7	11,3	11,7	12,1	12,9	13,4	13,8	14,3	14,7	15,1	15,9	16,9	17,9
..055	1,40	5,6	6,8	7,8	8,7	9,6	10,3	11,1	11,8	12,4	13,0	13,5	14,1	14,7	15,2	15,7	16,1	16,4	17,5	18,6	19,6
..06	1,47	6,0	7,4	8,6	9,6	10,4	11,3	12,1	12,8	13,6	14,2	14,9	15,5	16,0	16,6	17,2	17,7	18,0	19,2	20,4	21,5
..065	1,52	6,6	8,0	9,3	10,4	11,3	12,3	13,2	14,0	14,7	15,5	16,1	16,7	17,4	18,0	18,6	19,1	19,4	20,7	22,0	23,2
..07	1,60	7,1	8,6	10,0	11,2	12,2	13,2	14,1	15,0	15,8	16,6	17,3	18,0	18,7	19,3	20,1	20,7	21,3	22,3	23,7	25,0
..075	1,65	7,6	9,3	10,7	12,0	13,1	14,2	15,2	16,1	16,9	17,7	18,5	19,2	20,0	20,7	21,4	22,0	22,6	23,8	25,3	26,7
..08	1,70	8,0	9,8	11,3	12,7	14,0	15,1	16,1	17,1	18,0	18,9	19,7	20,5	21,3	22,0	22,8	23,4	23,8	25,4	27,0	28,5
..085	1,75	8,5	10,4	12,1	13,5	14,8	16,0	17,1	18,1	19,1	20,0	20,9	21,7	22,5	23,4	24,0	24,7	25,5	27,0	28,2	31,0
..09	1,80	9,1	11,1	12,8	14,3	15,7	17,0	18,0	19,2	20,2	21,2	22,1	23,0	23,9	24,7	25,5	26,3	26,7	28,5	30,3	31,9
..095	1,85	9,7	11,9	13,4	15,4	16,8	18,1	19,4	20,6	21,7	22,7	23,8	24,7	25,9	26,0	26,9	27,7	28,5	30,0	31,5	32,5
..10	1,90	10,0	12,3	14,2	16,0	17,4	18,9	20,1	21,4	22,5	23,6	24,6	25,6	26,6	27,5	28,5	29,4	29,8	31,8	33,7	35,6
..11	1,98	11,1	13,6	15,7	17,6	19,3	20,8	22,2	23,6	24,9	25,5	26,7	27,7	28,8	29,9	30,8	31,7	32,6	34,4	36,0	38,4
..12	2,08	12,1	14,8	17,2	19,2	21,0	22,7	24,3	25,8	27,1	28,1	29,4	30,6	31,8	32,9	34,0	35,0	36,0	38,0	39,8	42,4
..125	2,13	12,7	15,6	18,0	20,1	22,0	23,8	25,5	27,0	28,5	29,5	30,8	32,1	33,3	34,5	35,6	36,7	37,8	39,8	41,8	44,5
..13	2,16	13,2	16,1	18,6	20,8	22,8	24,6	26,3	27,9	29,4	30,8	32,2	33,5	34,8	36,0	37,2	38,3	38,9	41,5	44,0	46,6
..14	2,26	14,2	17,4	20,0	22,4	24,5	26,5	28,4	30,1	31,7	33,2	34,7	36,1	37,5	38,8	40,1	41,3	42,55	44,8	47,0	50,1
..15	2,34	15,1	18,5	21,3	23,9	26,1	28,3	30,2	32,1	33,8	35,6	37,2	38,7	40,2	41,6	43,0	44,3	45,6	48,0	50,4	53,7
..16	2,41	16,2	19,8	22,9	25,6	28,0	30,3	32,4	34,4	36,2	37,8	39,5	41,1	42,7	44,2	45,6	47,0	48,4	51,0	53,5	57,0
..18	2,54	18,2	22,3	25,7	28,8	31,5	34,0	36,4	38,6	40,7	42,0	43,9	45,7	47,4	49,0	50,7	52,2	53,75	56,6	59,4	63,3
..20	2,69	20,1	24,7	28,5	31,9	34,9	37,8	40,3	42,7	45,1	47,13	49,2	51,2	53,2	55,0	56,8	58,5	60,3	63,5	66,6	71,0
..25	2,99	25,2	30,9	35,7	39,8	43,6	47,1	50,4	53,4	56,4	59,1	61,8	64,3	67,0	69,1	71,3	73,4	75,1	79,8	84,0	89,3

NB: Nozzle output must not exceed 90÷95% of pump's output.

This manual will be useful for a correct maintenance, however it cannot be complete; for any problems do not hesitate to contact our **SERVICE DEPT.**

